

## LTVCHV 12

### Description:

This cylindrical vessel is installed on three adjustable feet, with efficient capacity of 1 200 l. This vessel is designed for final fermentation, storage and racking of beer.

### Accessories:

Oval manhole 340*420 mm	1.4301
Sanitary rotating shower with piping DN 25 mm	1.4301
Underpressure/overpressure armature DN 20	1.4301
Supply and discharge flap valve DN 32	1.4301
Upstream armature DN 32	1.4301
Blind flange DN 32, 1 piece	1.4301

### Parameters

Overall height	2 410 mm
Diameter	900 mm
Overall capacity	1 345 l
Empty weight	214 kg

### Warranty:

LT tank	36 months
Upstream armature	36 months

### Transport

This tank is usually shipped in horizontal position, fixed on special framing. Ground-plan frame dimensions: 2000\*1200 mm

### DOUBLE-ACTING VALVE

This double-acting valve can be installed in any position, however, it is mounted usually in a vertical position on a vessel top part, screwed in its threaded counterpart on the vessel, under use of proper thread type seal, usually with Teflon packing strips.

1. Body
2. Tube
3. Plate
4. Underpressure plate
5. Food seal EPDM
6. Bolt M6
7. Nut M6
8. Overpressure spring
9. Underpressure spring
10. Adjusting bolt
11. Locking washer

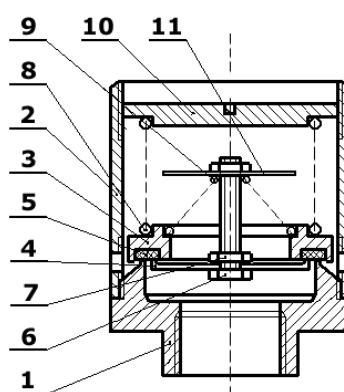

**Scheme**

